

## Bench Top Patty Maker

Model : WFP4013UV

The compact yet powerful Wedderburn bench-top patty maker is designed to form up to 4000 patties per hour. Expect a fast return on investment as you easily add value to your product with this affordable machine.

As with all Wedderburn products, the patty maker is designed with safety in mind, with built-in safety interlocks that prevent the user from sustaining injury.

### FEATURES

WFP4013UV

- up to 4000 patties per hour (variable speed)
- large 40 litre hopper capacity
- pneumatic wire cleaner
- 900 mm long conveyor belt
- precise portion control
- in-drum adjustment to easily adjust patty thickness/weight without the need for tools
- variety of standard shapes available including round, oval, square or sticks
- click-in/click-out drum interchange for easy exchange or cleaning of drums
- user selectable paper interleaving – great for non-stick stacking of patties, waxed paper is automatically placed under patties making patties easy to stack
- safe and efficient hands-free control of the machine via air-operated foot switch
- easy to disassemble for fast cleanup
- food contact parts are dishwasher safe

### OPTIONS

- single round – possible size range is between 56 mm and 130 mm in diameter
- design your own patty shape – submit a design that fits inside a 100 mm diameter circle, and we will have a drum made for you.
- WFPMDB03 Meat Balling Machine
- larger paddles for product feeding



Drums



Paper attachment



Easy-to-clean with removable parts



Operator panel



Specifications may change without notice

**SPECIFICATIONS**

Hopper capacity	40 litre
Speed	up to 4000 patties per hour (variable speed)
Conveyor belt (mm)	900 mm
Dimensions (mm)	1058 (W) x 637 (D) x 829 (H)
Electrical specification	230 V / 1-Phase / 50 Hz

**DIMENSIONS**

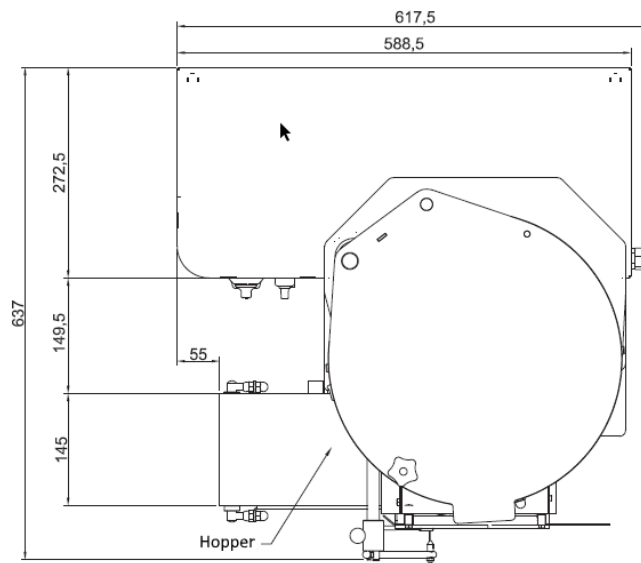

Top View

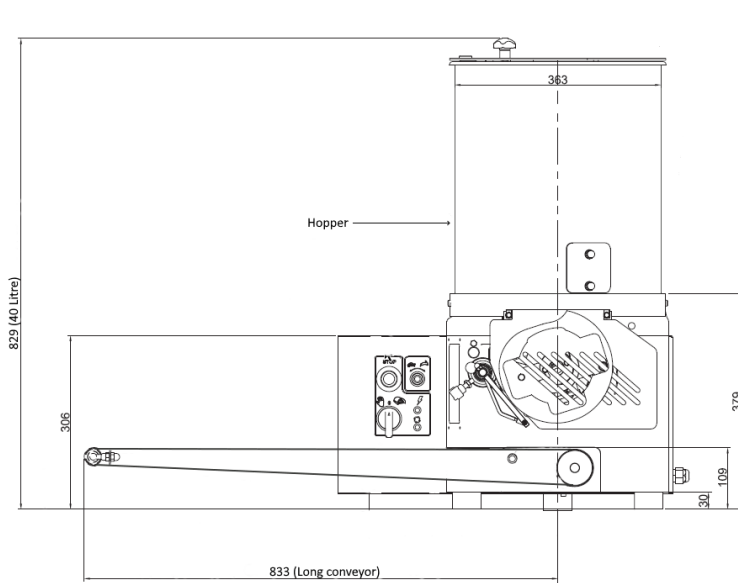

Front View

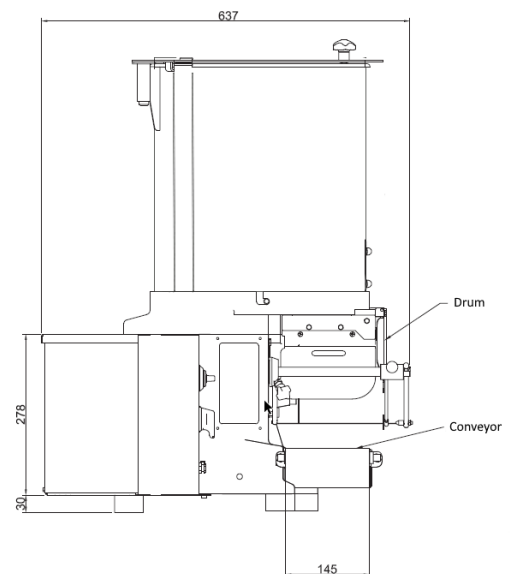

Side View

*Specifications may change without notice*