

Receipt Printing ECR Scale

Model : KTRM60P15K2MU

The RM60 is a price computing scale and cash register in one compact unit, with a maximum capacity of 15kg and a minimum increment of 2g. It has a built-in easy load thermal receipt printer, is trade approved, and will allow multiple operators to serve customers simultaneously.

FEATURES

KTRM60P15K2MU

- legal for trade use
- fast operation
- easy loading thermal receipt printer
- bright easy read alpha numeric operator LCD display
- bright easy read numeric customer LCD display
- stainless steel platform
- USB backup (memory stick supplied)

OPTIONS

- cash drawer
- rechargeable battery for up to 12 hours use (RD0305)



Scale shown with optional cash drawer

SPECIFICATIONS

Capacity:	15 kg
Graduations:	2g/5g (0-6kg x 2g, 6-15kg x 5g)
Platform Size (mm):	344 (W) x 242 (D)
Product Dimensions (mm):	365 (W) x 389 (D) x 373 (H)
Units of Measure:	kg
NMI Trade Approved:	Yes
Customer Display Type:	Numeric LCD with back light
Functions Keys:	On/Off, 24 x Preset PLU, Tare, Clear, Re-Zero, Sub-Total, Multiply, Clerk, Void, \$ Discount, % Discount, PLU, Paper Feed, Print, No Sale, Mode, Fix
Interface:	1 x AC Receptacle, 1 x 8V Cash Drawer port, 2 x RS232, 1 x USB, 1 x Ethernet 10/100
IP Rating:	N/A
Memory:	2MB
Operating Temperature:	-10°C - +40°C
Operator Display Type:	Alpha numeric LCD with back light
Paper roll size (mm):	57 x 45
PLUs:	10000
Power Supply:	240V AC (standard)
Printing Method:	Thermal
Print Speed:	75mm/sec (maximum)

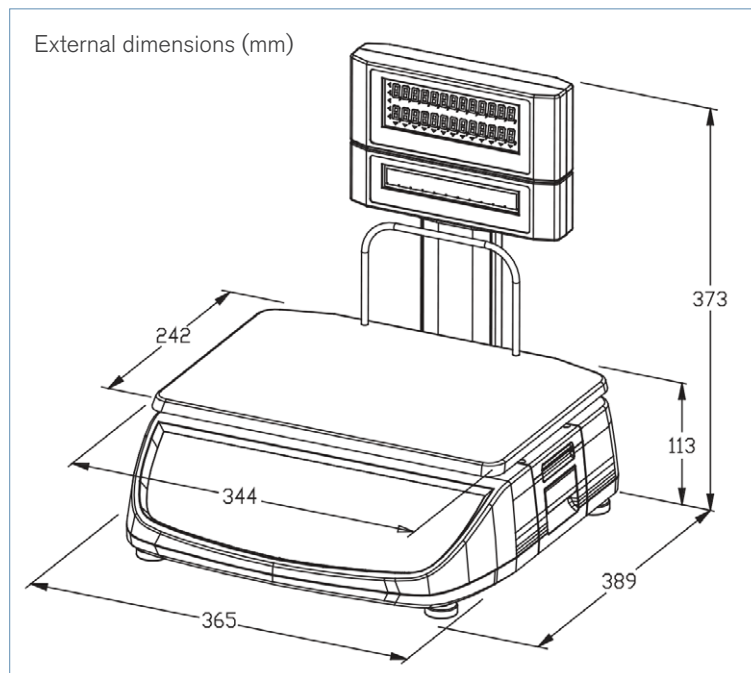

Specifications may change without notice.