

Digital Crane Scale

Model : WS604

WS604 Digital Crane Scales are engineered for safe overhead / lifting weighing in industrial environments. Packed full with useful functionality most of which can be controlled remotely through the infrared remote control, thus reducing the need to lower the Crane Scale every time you need to press a button or change a function setting.

FEATURES

WS604

- super bright 38 mm high red LED display
- aluminium die-cast housing
- supplied with infra red remote controller (as pictured)
- spare rechargeable battery
- 360 degree swivel hook
- zero, tare, hold functions
- low battery alarm
- overload alarm / record
- kg / lb weighing units
- sleep / idle mode
- auto off



VARIATIONS

| Model Number | Max Capacity | Graduation | Overall Dimensions (mm) |
|--------------|--------------|------------|-----------------------------|
| WS6041T | 1000 kg | 0.5 kg | 250 (W) x 220 (D) x 420 (H) |
| WS6043T | 3000 kg | 1 kg | 250 (W) x 220 (D) x 420 (H) |
| WS6045T | 5000 kg | 2 kg | 250 (W) X 220 (D) X 480 (H) |

Specifications may change without notice

SPECIFICATIONS

| | |
|---------------------------|-----------------------------|
| Legal for Trade Use | No |
| Scale Type | Overhead |
| Display Type | Digital Red LED |
| Display Size | 38 mm high |
| Display Range | Single |
| 2nd Remote Display | No |
| Weighing Units | kg, lb |
| Hook and Shackle Included | Yes |
| Hook Type | Swivel |
| Safe Overload Rating | 120% of rated capacity |
| Ultimate Overload Rating | 400% of rated capacity |
| RF Functionality | No |
| Remote Control Included | Yes |
| Battery Type | Rechargeable Battery |
| Environment Suitability | Dry |
| Overall Dimensions (mm) | 250 (W) x 220 (D) x 420 (H) |

DIMENSIONS

| DIMENSION | WS6041T | WS6043T | WS6045T |
|------------|---------|---------|---------|
| A | 70 mm | 70 mm | 70 mm |
| B | 100 mm | 100 mm | 100 mm |
| C | 35 mm | 35 mm | 35 mm |
| L | 420 mm | 420 mm | 480 mm |
| Net weight | 11.5 kg | 11.5 kg | 15 kg |

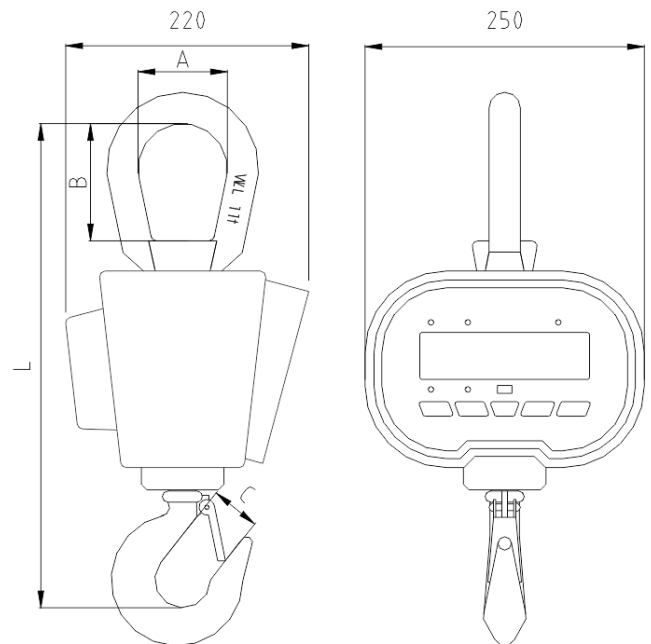

Specifications may change without notice